

Instructions for Assembling Saxon Armament's Reproduction Commando Stoner 63 Butt Stock.

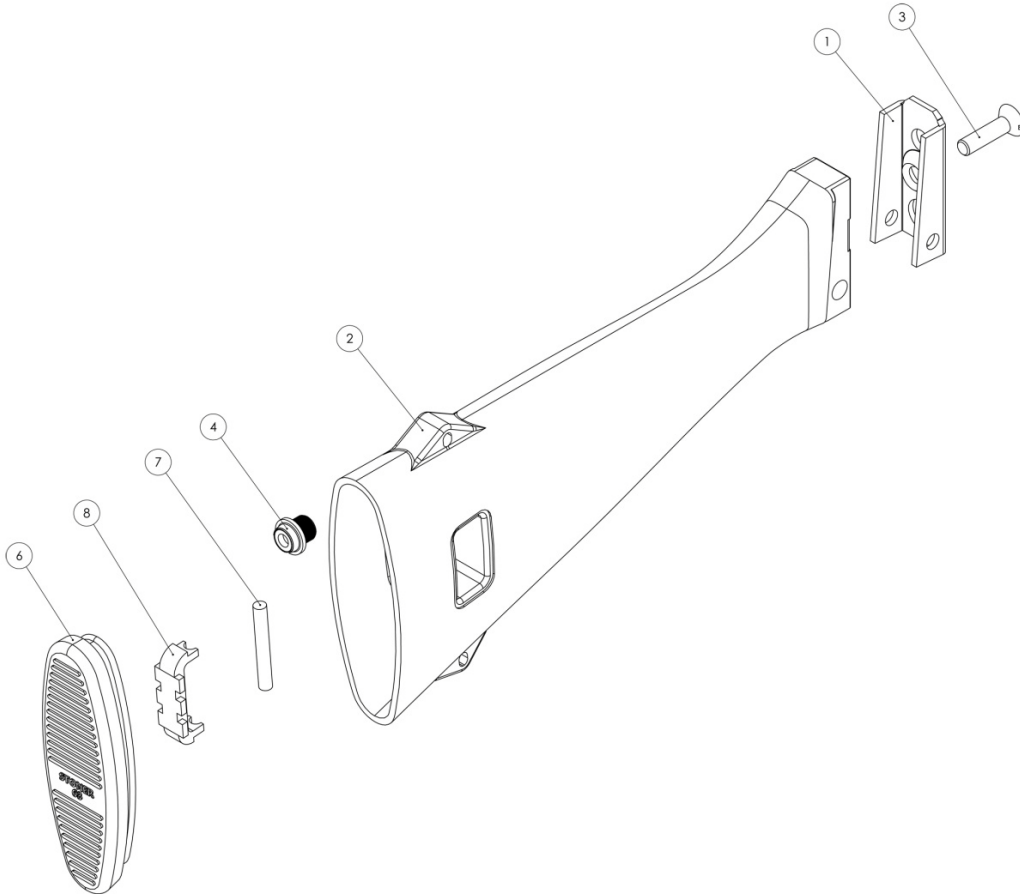

Item Number with Part Descriptions:

1. Part Number 2112 - Plate, Stock (**user supplied**)
2. Commando Butt Stock, Plastic (supplied in kit)
3. Part Number 2377 - Screw, Stock (**user supplied** 1/4 - 28 UNF -2A X 1" long flat countersunk head slotted machine screw - McMaster Carr stock number - 90275A561)
4. Part number 2322 - Nut, Stock (**user supplied** 1/4 - 28 UNF -2B self locking splined nut - Specialty Fasteners stock number - SPLNE-04-F)
5. Insulation (not shown, **user supplied, optional**)
6. Part Number 2114 - Pad, Butt Stock (**available separately**)
7. Number 7 drill rod (0.2010 diameter) 1.5" long (**user supplied** McMaster Carr stock number - 3009A217)
8. Window bar retainer (supplied in kit)

Tools required:

1. Large straight bladed screwdriver.
2. Possibly a file/sandpaper/knife for fitting the stock (2) to stock plate (1) interface.
3. Bonding agent suitable for joining nylon 12 and rubber together. (Suggested: Original Gorilla Glue)
4. Bonding agent suitable for joining nylon 12. (Suggested: Gorilla Super Glue)

Assembly Instructions:

1. Using 1/4"-28 threaded rod or a magnet on a stick, place the nut (4) inside the stock towards the front. Using the stock screw (3) start the thread and then partially seat the splines of the nut into the hole at the front of the stock (2).
2. Once the nut's (4) splines are partially seated into the stock (2) hole, unscrew the stock screw (3) and install the stock plate (1) onto the front of the stock (2).
3. Check fit of stock plate (1) against stock (2) ensuring the stock plate (1) full seats against the front of the stock (2). If it does not, modify the stock (2) a little at a time until it does using suitable means. Reinstall the stock screw (3) and tighten.
4. After tightening stock screw (3) against stock plate (1) and fully seating the spline nut (4), install the stock assembly onto the mounted trigger group and insert the stock retaining pin. Apply downward pressure on the rear of the stock (2) to test to make sure the spline nut (4) is fully seated. If the stock plate (1) becomes loose, retighten the stock screw (3) and repeat this step until the stock plate (1) no longer becomes loose.
5. Install the window bar (7) into the slot molded into the stock (2). Test fit to ensure that it fully seats into the slot provided.
6. Install the window bar retainer (8) into the slot and ensure that it fully seats. Make any minor adjustments to the window bar retainer (8) that are required.
7. Remove the window bar retainer (8) and apply bonding agent to the horizontal tabs forward faces. Reinsert the window bar retainer (8) into the stock (2) ensuring it fully seats.
8. **Optional** - If desired, install the desired type of insulation material inside the stock (2) leaving enough room for the butt pad (6) to be fully seated.
9. Test fit the butt pad (6) into the stock (2) and correct any fitment issues detected.
10. Remove the butt pad (6) and clean the mating surfaces of the butt pad (6) and the stock (2).
11. Apply bonding agent to the inside of the stock (2) where the butt pad's (6) rib touches when it telescopes into the stock (2) (follow bonding agent's instructions on its use). Firmly press the butt pad (6) into the stock (2) and seat it fully. Clean up any excess bonding agent. Allow the assembly to dry.
12. Mount stock assembly to the trigger frame using the standard method.